



## Instruction Manual

# Porter Series Controllers

PT2-05 / PT2-010 / PT2-010XX/XXX

## Contents

Section	Page	Section	Page
1. Models.....	2	6. Battery and Motor Current ...	6
2. Do's and Don'ts.....	2	7. Mounting .....	6
3. Wiring .....	3	8. Dismantling.....	7
4. Power Connections .....	4	9. Service.....	7
5. Throttle wiring .....	4	10. Specifications .....	8

# 1. Models

The Porter is a simple, single direction controller designed for electric bicycles, golf caddies, small material handling machines, electric wheelbarrows and other similar applications.

It has extremely simple wiring and operates over a wide battery voltage range (12v to 48v) so it is a very versatile controller. It also accepts either a Hall effect throttle or a resistive potentiometer.

# 2. Do's and Don'ts

## Do

- **Do** read the instructions thoroughly before installing the controller.
- **Do** fit motor suppression components [see our website for details].
- **Do** twist the motor wires together if possible.
- **Do** use proper 6.3mm push-on connectors. 4QD can supply a suitable lead set.
- **Do** be aware that motor current is (sometimes much) greater than battery current.

## Do not

- **Do not** allow the pot wires to short to ground or B+. This could damage the controller.
- **Do not** allow water to enter the controller or contact the board.
- **Do not** turn acceleration or deceleration adjustments fully clockwise (fast), we suggest no further than 9 o'clock (diagram shows them central at 6 o'clock).

### 3. Wiring

Just seven connections are needed and are shown in the diagram below.

Motor + (internally connected to Battery +)

Motor -

Battery +

Battery -

3 wires for speed pot and ignition.

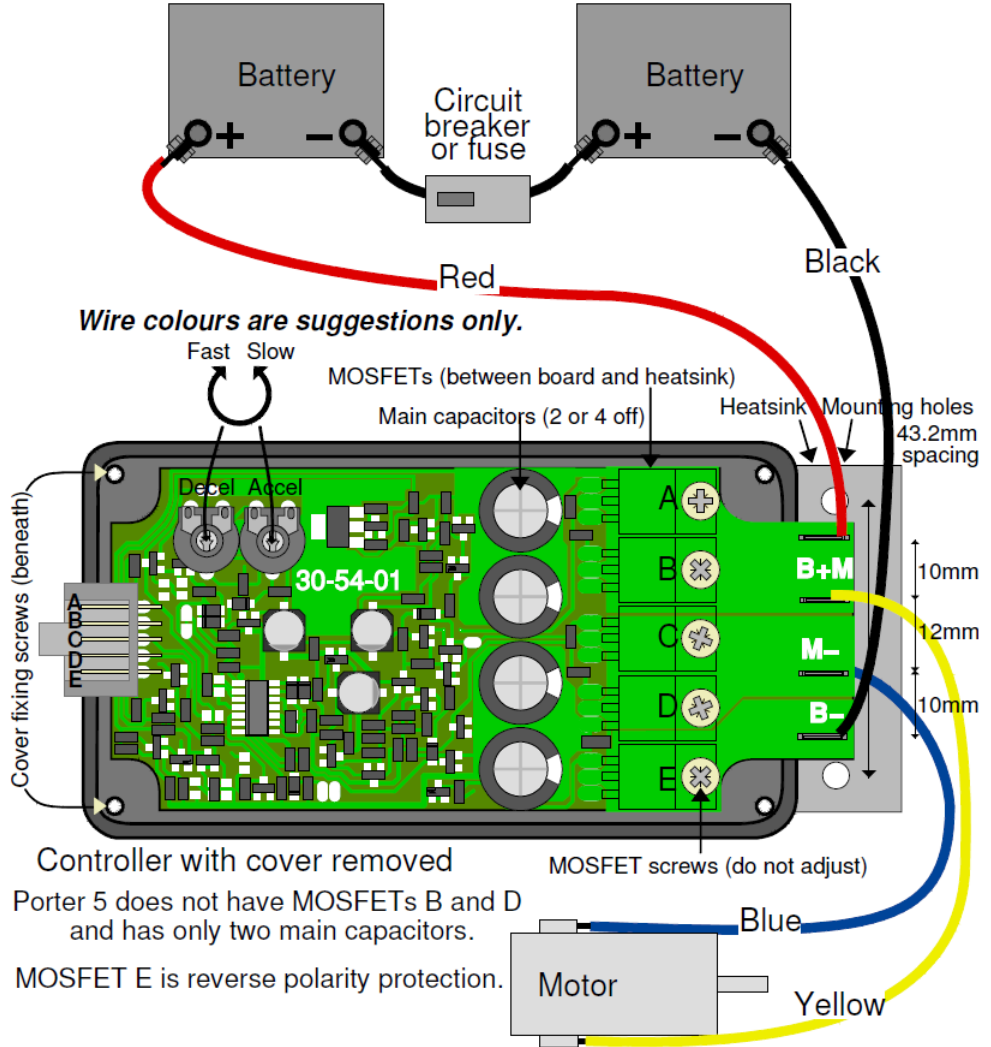

Figure 1: Porter Wiring

## 4. Power Connections

2.5mm<sup>2</sup> cable is adequate for most applications of the Porter 5, but 4mm<sup>2</sup> or 6mm<sup>2</sup> may be preferred, especially for the motor and for the Porter 10.

**Caution** Take care when connecting the battery and motor wiring - connecting a battery wire to a motor terminal can destroy the controller.

### Motor Wiring

If the motor rotates in the wrong direction, exchange M+ and M- wires.

We recommend keeping the motor wires close together, and if possible twisting them together. If one is not already fitted, we also recommend fitting a 10nF 100V disc ceramic motor suppression capacitor across the brushes of the motor.

### Battery Wiring

Keep the battery wiring as short as possible. The Porter is protected against reversed battery (60v max) but will not work with the battery reversed. Again, keep the motor wires close together and twisted together if possible.

### Battery Circuit Breaker or Fuse

A circuit breaker or fuse is advised in the battery connections, to act as an emergency disconnect in the event of a fault in wiring or any other component. In some applications such a circuit breaker is a legal requirement.

A sensible rating for this breaker is the same as the motor's continuous current. Otherwise a 30 amp breaker should be adequate for most uses with the Porter 5 or 60 amp with the Porter 10.

## 5. Throttle Wiring

The Porter can be operated by a 10k potentiometer as below

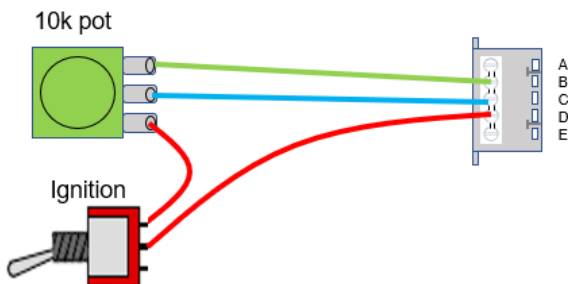

A 5k pot such as our Magura twistgrip is best connected to A, C, and E, [Black – A, brown – C, blue – E].

Internally the Porter has resistors connected to A and E to reduce the dead areas at each end of the travel of a 5k pot.

## Connections

Pin	Function
A	1k5 resistor to pin B
B	0v (internally connected to battery –ve via reverse polarity protection MOSFET)
C	Speed voltage from pot (1-4V)
D	5V. This can feed up to 10mA at a battery voltage of 24V or lower.
E	1k5 resistor to pin D

## Hall Effect Throttle

Connects to pins B, C and D. Pin D has 5v present to feed the hall device.

It should be the type that gives 1v at zero speed and 4v at full speed. Some throttles are reversed and will not be suitable. The max permissible hall current is 10mA, [you may need to fit a suitable resistor in series with pin D]. There are many makes of Hall throttles and wiring colours are not standardised.

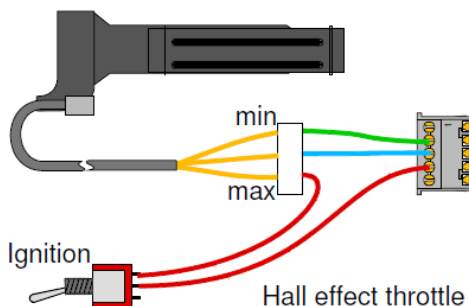

## Ignition Switch

An ignition switch should be connected in the pot or throttle circuit to switch off the controller when not in use. Without this switch the controller is still powered up and drains about 17mA from the battery.

When ignition is switched off, the controller will ramp the motor down to zero speed (at whatever deceleration rate you have set) and then switch itself off.

## Voltage Input

The Porter may be fed from a voltage source between 1V and 4V. This can be PWM supplied from a microcontroller or even 4QD's own DMR-203 radio control interface. The controller will react to the DC average value of the applied waveform. A 10K resistor is required to activate the internal ignition, connected as shown.

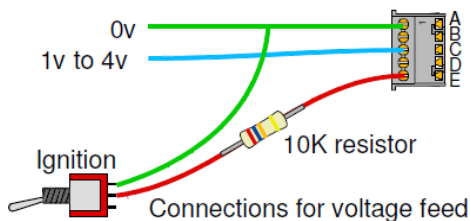

More details of how to control the Porter from a microcontroller are in the knowledgebase on our website.

## Adjustments

There are two adjustments as shown on page 3. These control the rates at which the motor accelerates and decelerates. Optimum setting depends on your machine but do not choose too fast a rate or you may get jerky and unsafe performance.

## Pot Fault Protection

The Porter incorporates protection such that it will not fail to full speed if the pot goes faulty or a wire brakes. However if the pot zero wire breaks, then the controller will ramp down very slowly to zero speed and, as it does this, the speed pot will have little effect. If this happens, use the ignition switch to ramp down at whatever rate you have the deceleration ramp set to.

## 6. Battery and Motor Current

Be aware that, except at full speed, the battery current will be less than the motor current, and the motor voltage less than the battery voltage.

The motor current times the motor volts is the same as battery current times the battery volts.

At full speed, motor current should not exceed 100 amps, and that not for long, or the reverse battery MOSFET will be destroyed, damaging the circuit board.

The instantaneous motor current limit is much higher than this on the Porter 10.

## 7. Mounting

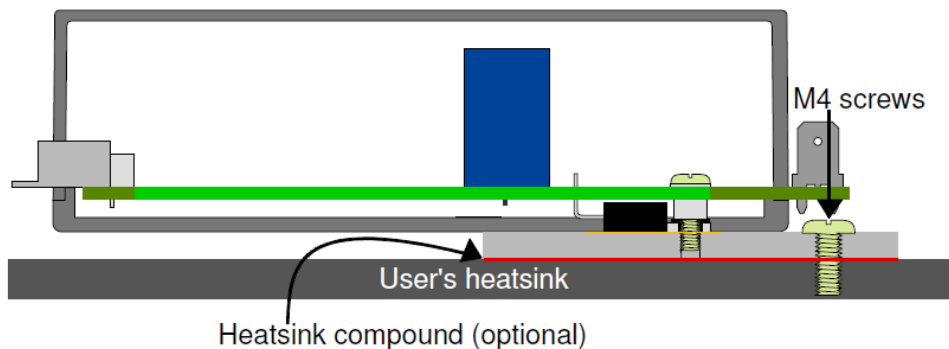

The flat aluminium plate should be bolted onto the metalwork of the machine to act as an additional heatsink, as shown above.

Mounting holes are 43.2mm apart and are 4.2mm diameter for M4 screws. The current the Porter gives reduces as the MOSFET (heatsink) temperature increases, so a large, thick heatsink, with good air-flow, will increase the length of time high current can be used. Heatsink compound (thermal paste) should be used between the Porter's own heatsink and your additional one to increase heat flow between them, especially at high currents.

The length of time for which maximum current can be drawn is limited by the speed with which heat can be removed from the integral heatsink to the extra heatsink. As a rule-of-thumb, the heatsink should not be allowed to get too hot to touch.

### **Water Resistance**

The box is not sealed, so some thought must be given to mounting it if water is likely to get at it. The box is best mounted horizontally but guard against water falling on the connectors or running down leads and thus into the connectors.

## **8. Dismantling**

Remove the two cover fixing screws (shown on page 3). Pull the cover away from the heatsink. The cover can now be slid off the 5 way connector.

Re-assembly is the reverse of this. Make sure the cover is correctly aligned with its plastic base and push firmly together at the heatsink end - the board is a close fit into the cover.

If you ever need to remove the heatsink from the PCB please be sure to note carefully the arrangement of the black and white insulating washers. After re-assembly make sure there is no connection between the heatsink and the centre pins of all the MOSFETs.

## **9. Service**

In the event of any problem please contact us before returning a suspect controller. Please include a completed returns form with the returned controller [see website]. Details of service charges are on the website.

### **Warranty**

All our controllers have a warranty against defective manufacturing for 12 months from the date of shipment. The warranty doesn't cover damage caused by incorrect installation.

## 10. Specifications

Model	Porter 5	Porter 10
Nominal voltage range V	12 – 48	
Minimum / maximum voltage V	10 – 55	
Motor current A [max]	95	190
Motor current A [1 minute]	75	120
Motor current A [continuous]	50 [depends on mounting / cooling]	100 [depends on mounting / cooling]
Regen braking	Y	
Dimensions [mm]	136 x 62 x 35	
Weight [g]	140	
Power connections	6.3mm push-on blades	
Input	5k to 25k pot, 0 – 4V, Hall effect 6mA max @48V	
Reverse polarity protection	Y	
Overvoltage protection	Y [68V]	
Under voltage protection	Y [8V]	
Pot fault protection	Y [>50k]	
Current limit – drive	Y	
Ramping	Acceleration and deceleration adjustable between 0.1S and 5S	
Power down state (motor)	Diode	
Ignition, Electronic	pot	
Heatsink	Basic integral	
Switching frequency	20 kHz	
Quadrants	2	