



## Instruction Manual

# Reversing Hand Throttle and Horn Relay Board RBT / HRB

## Contents

Section	Page	Section	Page
<b>1. Introduction .....</b>	<b>2</b>	<b>4. Reversing Hand Throttle (RBT) .8</b>	
<b>2. Do's and Don'ts .....</b>	<b>2</b>	4.1 Chassis Lead Connections .....	9
<b>3. Horn Relay Board .....</b>	<b>3</b>	<b>5. Wiring.....</b>	<b>10</b>
3.1 HRB Versions.....	3	5.1 24v Motor, Lights and Horn.....	10
3.2 HRB Mounting.....	3	5.2 24v Motor with 12v Lights/Horn ..	11
3.3 HRB Operation.....	4	5.3 Use with Pro-150 Controller.....	12
3.4 Catching Diodes.....	4	5.4 Use with 4QD Series Controllers	12
3.5 Schematics.....	5	<b>6. Service .....</b>	<b>12</b>
3.6 HRB Board Layout .....	6	6.1 HRB .....	12
3.7 HRB: 36V Operation.....	7	6.2 RBT.....	12

# 1. Introduction

This manual covers the horn relay board (HRB) and the reversing hand throttle (RBT), which are often used together.

The relay board is primarily aimed at model locomotives, in conjunction with the hand throttle, to operate twin horns and lighting. The relay board's operation is independent of the speed controller - it is worked by two wires from the hand throttle.

However the design of the relay board is extremely versatile and it may be used without the hand throttle. It will also find uses in industrial machine control and other applications where a small relay board is required.

# 2. Do's and Don'ts

## Do

- **Do make sure that the plug on the RBT is correctly aligned with the socket before pushing it in.** 
- Make sure that you have broken link K on the HRB board if you are using 12v horns on a 24v system.
- Mount the HRB board somewhere where dirt and water won't get to it.
- Fit catching diodes across the horns.

## Do not

- **Connect the frame connection of the horn to the centre (CO) terminal.** Horn frames are often live and therefore the two frames may be connected together through your mounting. Operating either horn in this situation will effectively short out the battery via the horn board and relays. This may destroy the horn relay board.
- **Connect any two CO contacts together.** Doing so will destroy the board when either relay is operated - unless the appropriate links are scratched through.
- Misalign the RBT plug with its socket. This can blow fuse tracks in the controller, or damage the track in the pot.

## 3. Horn Relay Board

### 3.1 HRB Versions

There are 12V and 24V versions of the horn relay board, and each can be supplied with either 3 relays (for use with lights and twin horns), or 4 relays (the additional relay can be used, for example, for reversing lights).

#### **24V Systems (HRB-324 / 424)**

The HRB-324 and HRB-424 are versions with either 3 or 4 24v relays, suitable for use with 24v systems. They can be used with 12v accessories by cutting link K on the PCB.

#### **12V Systems (HRB-312 / 412)**

These are versions with either 3 or 4 12v relays, suitable for use with 12v systems. The wiring diagram for the 4 relay versions is available in the knowledgebase on our website.

### 3.2 HRB Mounting

The HRB is supplied with plastic mounting pillars. It requires 4 off 4mm diameter holes in a rectangle 68mm x 53 mm.

Make sure nothing touches the underside of the HRB - this could cause a short circuit.

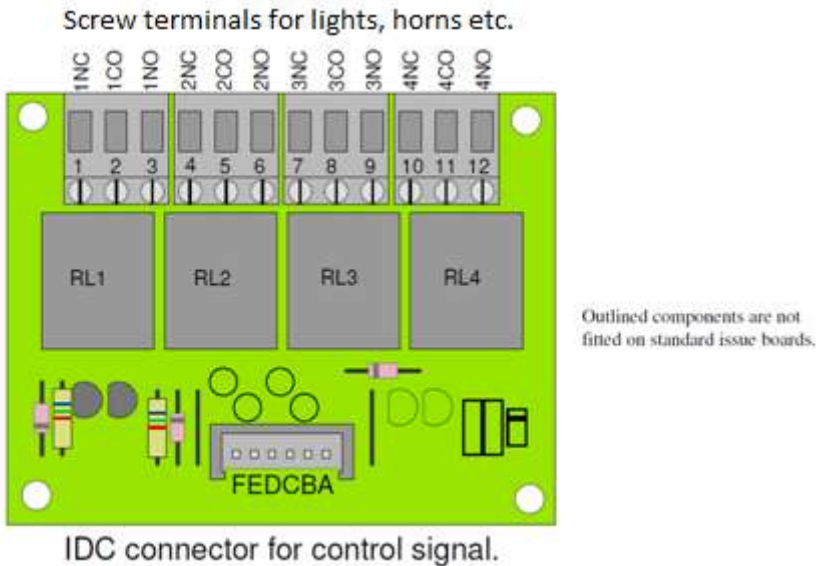

Figure 1: HRB-424 Top View

### 3.3 HRB Operation

A six way input connector is used, though normally only two pins are used. The extra four pins are provided to add to the board's versatility.

Connections are as below.

( ) indicates that the connection is not normally used

[ ] indicates alternative function which may be obtained by altering the board.

Pin	Purpose	Alternative Use
A	(Battery negative)	
B	RL3	[RL4]
C	RL3	
D	RL2 and RL1	[RL2]
E	RL2 and RL1	[RL1]
F	(Battery positive)	

RL1 and RL2 are operated via a single wire to either input pin E or pin D. Two pins are used so it is possible to split operation and have the relays operating separately (not a feature of the standard board).

Connecting one of these pins to B- (battery -ve) operates RL1 and connecting it to B+ (Battery +ve) operates RL2.

Connecting pin C or B to Battery - operates RL3.

The relay contacts are rated at 12A resistive load.

### 3.4 Catching Diodes

Many horns are inductive. These will cause electrical noise and will shorten the life of the relay contacts. In extreme conditions, the electrical noise can blow transistors on the relay board, or even cause the controller to fail. We therefore recommend you fit 'catching diodes' across the horns. Diode type 1N4002 or similar is readily available. Diode's Anode (marked with a white band) connects to horn +ve (yellow wires in diagrams). More information is available in the knowledgebase on our website

### 3.5 Schematics

Below is the schematic of the board showing the relay contact wiring. The relay board schematic corresponds best with the physical layout of the relay board if this is viewed from the copper (soldered) side.

Notice the break-points marked A through L. These are present so that the relay contacts may be isolated as required, and the relay coils may be powered from the 6 way input connector, for uses other than described herein.

Note RL4 and the components shown in blue below are not fitted on the standard board: the screw connector associated with RL4 is used for supplying battery power to the relay coils and/or the relay contacts. On 4 relay versions Tr4 is replaced by a wire link and RL4 and diode are fitted.

Please note that 4QD can take no responsibility for alternative wiring schemes. The information here is given in good faith and if you break these points or modify the board you do so entirely at your own risk.

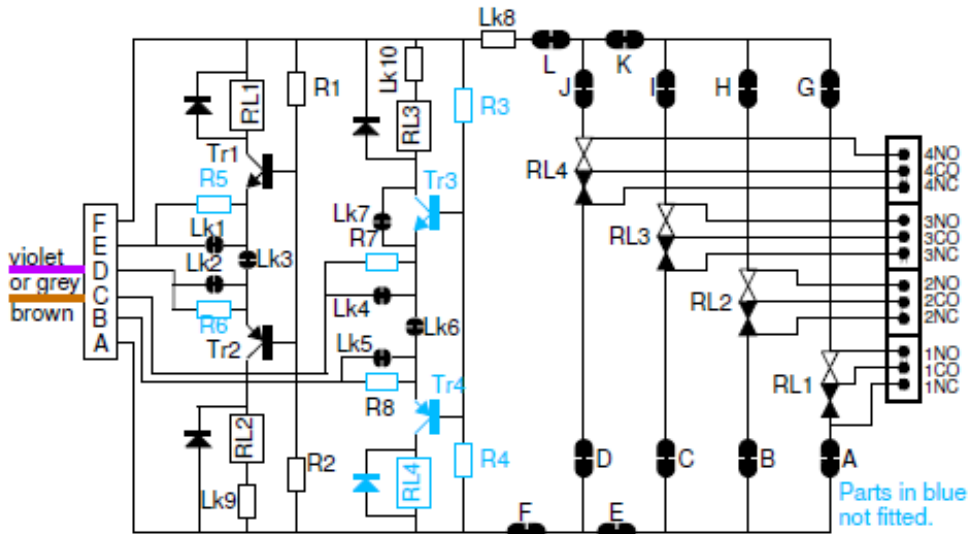

Figure 2: HRB-424 Circuit Diagram:

### 3.6 HRB Board Layout

The board layout below is given to help locate the links and other features mentioned in the text. This diagram on the left is as viewed from the component side, with the board transparent so the copper underneath can be viewed. Not all components shown are fitted - see circuit diagram. The diagram on the right shows the underneath of the board. Link K is marked in red.

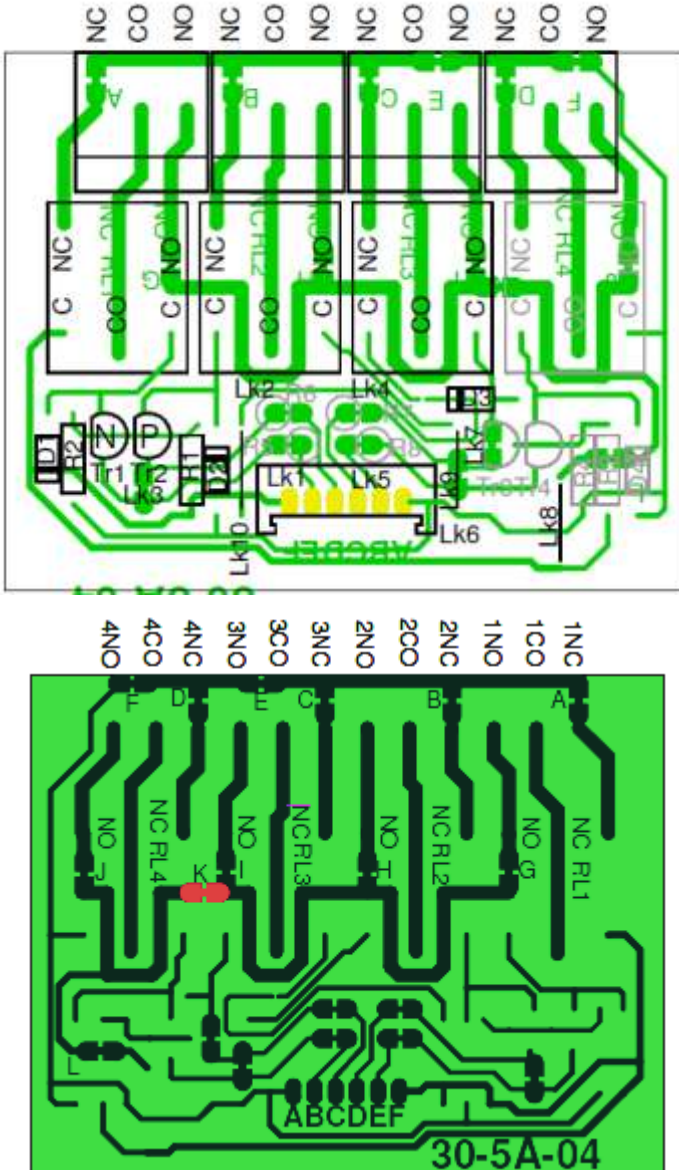

Figure 3: HRB Layout Diagram

### 3.7 HRB: 36V Operation

The standard board has relay coils for 24v operation. However if the appropriate series resistor is fitted, these can be operated from 36v instead of 24v.

There are 4 possible resistor positions, R5, R6, R7 and R8 on the circuit. There are positions for the resistors just behind the 6 way input connector. Resistor positions are shown right. Beneath each resistor is a scratch-through link which must be broken to engage the resistor.

With the standard wiring, only R6 and R7 will be used. However, to prevent mis-wiring blowing the board it is suggested that all four scratch through links be broken.

For 36v operation, 820 ohms 1/4 watt should be suitable (relay coil resistance is about 1600 ohms). When modified thus, the same wiring is used as for the 24v system with the 12v tap (if required) done the same way as for a 24v battery (see *Figure 9*).

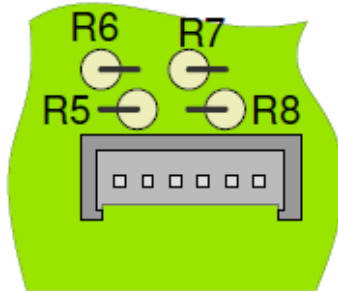

*Figure 4: HRB 36V Resistor Location*

## 4. Reversing Hand Throttle (RBT)

A diagram of the hand throttle is shown below: its operation is straightforward, with a rocker switch to select forward or reverse, and toggle switches for accessories e.g. lighting and horns.

The hand throttle has no ignition switch (refer to speed controller instruction manual). To switch off the controller the hand control box should be unplugged. If a separate ignition switch is required, then this should be inserted in the yellow wire.

The RBT comes in 3 versions, 12V, 24V and 36V.

It contains a built-in LED voltmeter. The LEDs are all illuminated at full battery voltage and they dim and extinguish one by one as the battery discharges.

The LED voltages are shown below: at the higher voltage the LED starts to dim and is entirely off at the lower voltage.

**It is important that the 8 pin plug is correctly aligned** with the socket before pushing it home, forcing the plug in in the wrong orientation may blow the fuse tracks on the controller or damage the pot track.

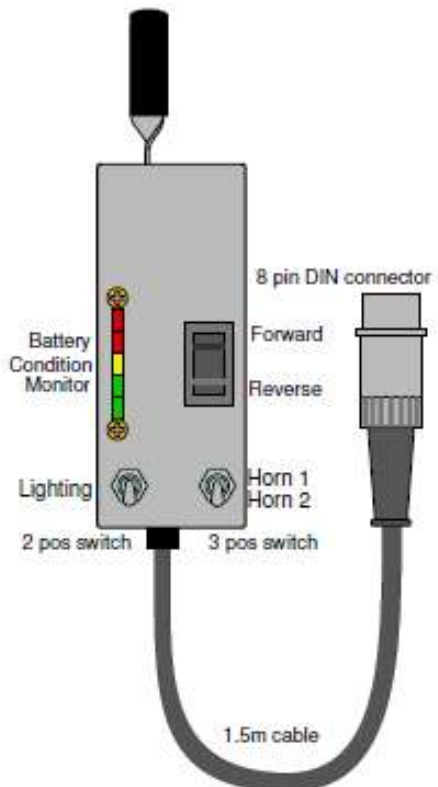

Figure 5: RBT Diagram

Light	Voltage-24V 5 LED	Voltage-36V 5 LED	Voltage-12V 3 LED
Green	25.1 - 24.6	37 — 36.5	12.3 — 11.8
Green	23.3 - 22.8	35 — 34.5	
Yellow	21.5 - 21.0	34 — 33.5	10.3 — 9.8
Red	20.7 - 19.2	33 — 32.5	
Red	18.9 - 17.4	32 — 31.5	9.0 — 8.5



The wiring connections and colours for the RBT are shown below:

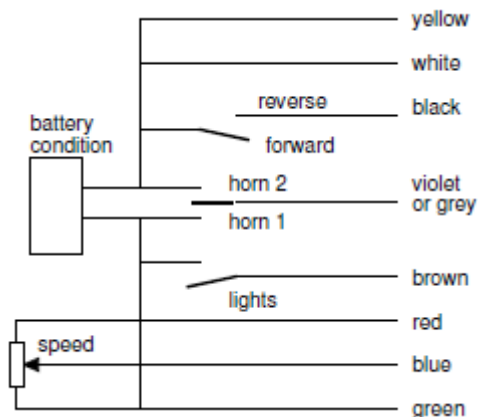

Figure 6: RBT Wiring Diagram

#### 4.1 Chassis Lead Connections

The chassis lead (CLM-806) is the cable provided to connect the RBT to the speed controller, and to the HRB if installed.

The wiring connections and colours are shown below. Note that there is a white plastic filler in the centre of the 6 core cable, to maintain its shape.

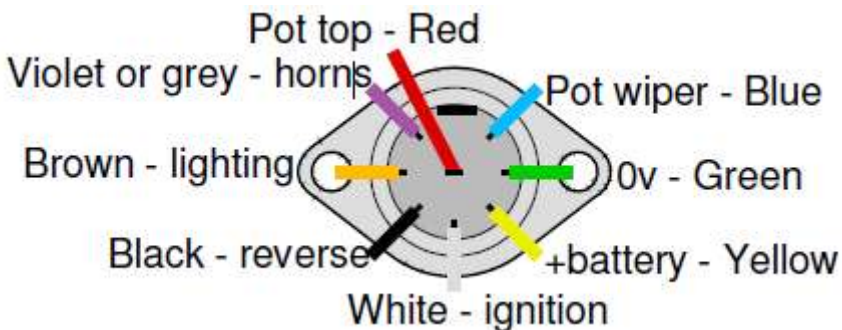

Figure 7: View of connections to chassis mounted DIN socket

## 5. Wiring

### 5.1 24v Motor, Lights and Horn

The diagram below shows the wiring with hand control box, and speed controller. As below, the standard board operates from 24v and must use 24v horns and lighting.

Wiring for the 12v board with 12v accessories is the same.

Notice the 'Auxiliary Fuse or circuit breaker' - this is to protect the lighting and horns and their wiring and should be rated at no more than 10 amps.

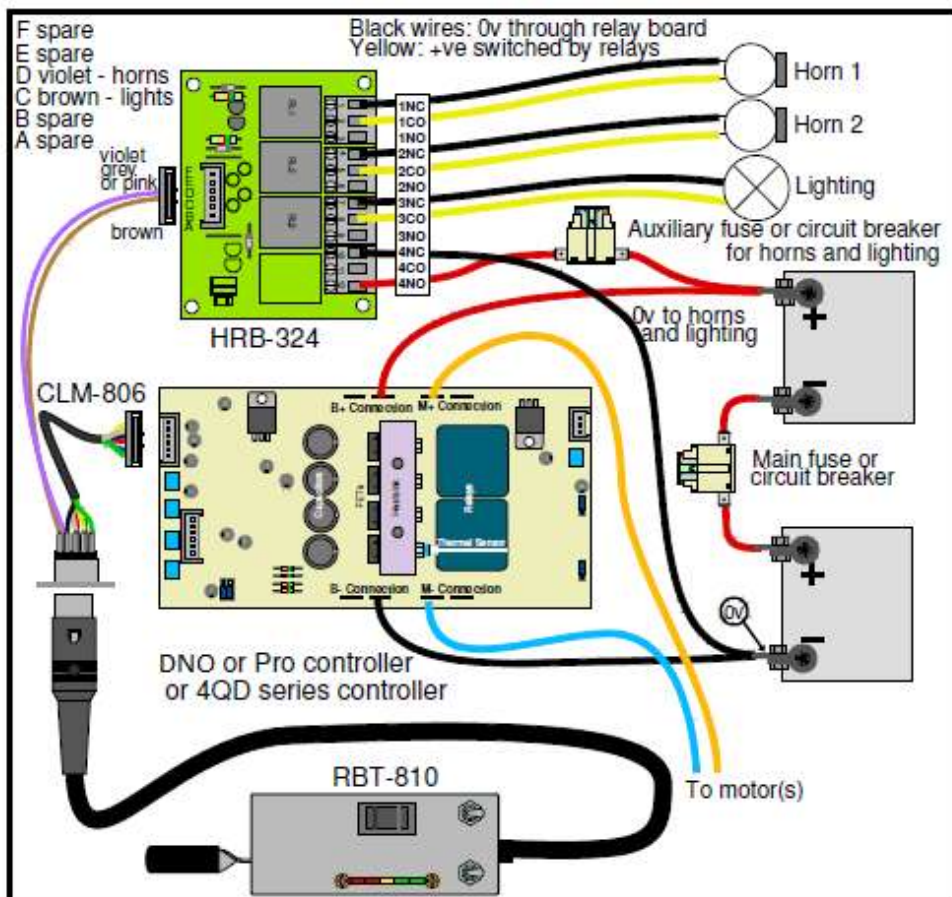

Figure 8: Standard 24V Wiring Diagram

## 5.2 24v Motor with 12v Lights / Horn

The diagram below shows the wiring you should use if you have a 24v system but have 12v horns and lighting.

Notice the 'Auxiliary Fuse or circuit breaker' - this is to protect the lighting and horns and their wiring and should be rated at no more than 10 amps.

**Note:** *scratch-through link marked 'K' must be broken beneath board where arrowed. Failure to do this will blow tracks on the board*

Breaking link K will change the voltage to all 3 relays (RL1. RL2, RL3).

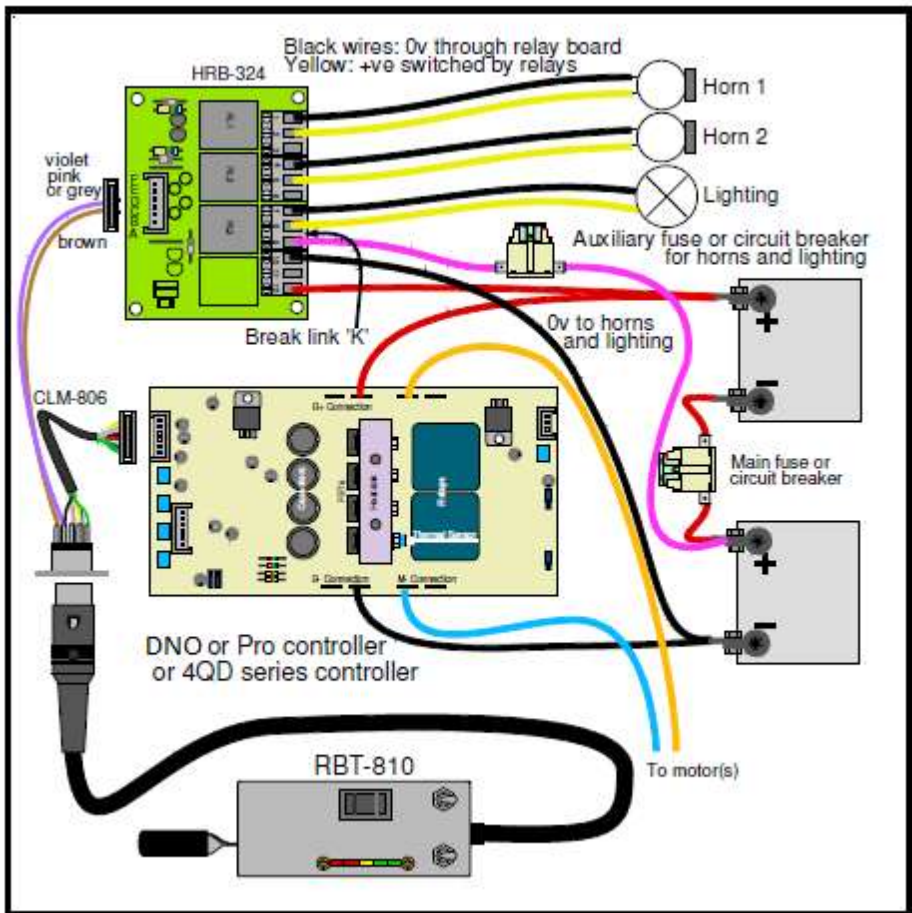

Figure 9: 12V Horns & Lighting Wiring Diagram

### 5.3 Use with Pro-150 Controller

The wiring diagrams in Figures 8 & 9 are unchanged, the only difference is that the BCM will read about 0.6 v less than battery voltage.



### 5.4 Use with 4QD Series Controllers

The wiring diagrams in Figures 8 & 9 are applicable, but the single 6 way connector is replaced by a 4 way and a 6 way connector as shown below.



## 6. Service

### 6.1 HRB

The HRB is very simple: there is little to go wrong. However external faults may causes excess currents and the links (which are intended as scratch-through options) may then act as fuses, so if you have a problem, inspect the lettered links. If they do fuse, they can be repaired with fine wire: a single strand from a 7/02 wire is suitable. The most common fault with the HRB is TR1 or TR2 being blown due to incorrect wiring or short circuits. It is worth checking these and they are easy to replace. Test instructions are in our knowledgebase on the website. The HRB is inexpensive, it is not economical for 4QD to repair.

### 6.2 RBT

The hand throttles are very reliable but the pots in them do wear out after a lot of use [they are rated for 10,000 cycles]. If the throttle operation becomes intermittent then consider replacing the pot.

## Warranty

All our products have a warranty against defective manufacturing for 12 months from the date of shipment. The warranty doesn't cover damage caused by incorrect installation.