



Instruction Manual

4QD Series Controllers

4QD-300-48

Section	Page	Section	Page
1. Introduction	2	9. Braking	14
2. Do's and Don'ts	2	9.1 Parking brake.....	14
3. Safety	3	9.2 Mechanical brake.....	14
4. Fitting	3	10. Adjustments	15
4.1 Waterproofing	4	10.1 Gain	15
5. Features	5	10.2 Ramps	15
6. Power Connections	6	10.3 Current limit.....	16
6.1 Battery & motor wire size	6	10.4 RAT.....	16
6.2 Battery Wiring	6	10.5 Reverse Speed.	16
6.3 Under voltage protection.....	7	10.6 High pot lockout [HPLO]	16
6.4 Motor Wiring.....	8	10.7 Regen brake defeat.	16
6.5 Noise suppression	8	11. Heatsinking and Output Current ..	16
7. Control Connections	9	12. Battery Charging	17
7.1 Simple Wiring Diagram	9	13. Fault Finding	17
7.2 Ignition light.....	11	14. Fuses	18
8. Inputs	12	15. Link positions	18
8.1 Speed control pot.....	12	16. Dismantling	19
8.2 Reverse.....	13	17. Service	19
8.3 Inhibit	13	18. Specifications	20

1. Introduction

The 4QD-300 is a heavy duty 4 quadrant motor speed controller for currents up to 300A. It is suitable for larger model locomotives, battery powered vehicles, electric boats, and any application that needs a really powerful controller. It is fully electronic with no internal relays, and has many fail-safes built in for reliable long term use. The standard heatsink is suitable for most applications, but for high current operation for longer periods there are air-cooled, and water-cooled options available.

2. Do's and Don'ts

Do

- Adjust the gain, acceleration and deceleration settings to suit your requirements.
- Fit the cover after setup to stop contamination entering.
- Fit an emergency battery disconnection switch for safety.
- Make sure the terminal nuts are tight – high current through a loose connection will burn it.
- Keep the motor in good condition. Worn brushes can blow the controller.
- Fit motor suppression components. See our website for details.
- Consider fitting the reverse polarity protection system described later.
- Please be careful – these are powerful controllers that can give very large currents.

Do not

- Drill or modify the metal base without removing it from the controller, swarf can kill the controller.
- Test the controller without securing the top board in place.
- Connect the batteries with the ignition on. The ignition is also a reset switch if the controller trips for any reason.

3. Safety

Any vehicle intended to haul or carry passengers should be fitted with the appropriate safety systems, and it is the customers responsibility to provide these.

All systems should have

- A fuse appropriate for the expected current draw of the system.
- A battery isolator switch, ideally within reach of the user to allow emergency disconnection.

Circuit breaker / fuse

In practice circuit breakers and fuses aren't fast enough to protect semiconductors, so may not offer the controller full protection. They will however protect the wiring from short circuits, and a circuit breaker can also act as an isolator switch to disconnect the battery.

Any breaker in the battery line should not be routinely opened while the motor is running as the motor can generate a very high voltage which will stress the controller.

Battery Contactor

Due to their high current capabilities the 4QD series do not have reverse polarity protection built in, and will be damaged if the battery is connected the wrong way round. If reverse polarity protection is required, we have a battery contactor circuit in the knowledgebase on our website that shows how this can be done.

4. Fitting

It is suggested that the electrical system not be earthed to chassis. Although 4QD-series controllers are isolated from the heatsink, an isolated chassis will make the installation more tolerant to faults occurring elsewhere in the system.

Slots are provided at the ends of the controller's base for mounting. These will accept an M5 or M6 screw. When mounting the controller take care that the heads of the mounting bolts do not short to any of the controller's internal busbars.

If other mounting holes need to be drilled, take care that no swarf gets onto the circuit boards. It is best to dismantle the controller if this needs to be done, instructions are in the knowledgebase on our website.

The cover is supplied loosely fitted. It is designed to be more permanently fitted with the 2 strips of double sided adhesive tape once all adjustments have been completed.

4.1 Waterproofing

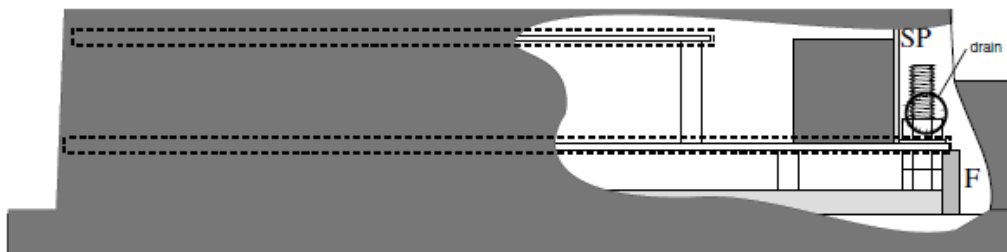

Water must be kept away from the electronics, most water problems are caused by condensation or splashing.

The plastic cover of the controller is waterproof and will keep off water from above. The ends of the controller are sealed with a piece of waterproof foam between board and base (F in the above diagram of the 4QD-200)

Behind the terminals is a plastic splash plate (SP in diagram). A notch is present in this for control wires to pass through. For best splash proofing this plate should be sealed to the board using silicone rubber once installation is complete.

The controller is best mounted with the aluminium base horizontal at the bottom so water cannot run into the controller and collect inside the cover. Mounting with the base vertical is permitted but we have seen controllers fail because water was allowed in and was held by capillary action between the boards and the cover in the area shown by the dotted lines. A drainage hole ('drain' on the diagram) will allow water to run out. Also the splash plate can be sealed to the side of the cover with silicone rubber.

Do not try to seal the base to the cover: this should be allowed to breathe so that any condensation can escape.

In any machine likely to be exposed to water you should consider where will the water come from and where it will go. Water can run along cables into the controller, connectors or other sensitive point. This can be prevented by making a small loop so the water drips off at the low point before it reaches the controller.

A conformal coating can be applied to the circuit boards which can help protect the controller in damp environments.

5. Features

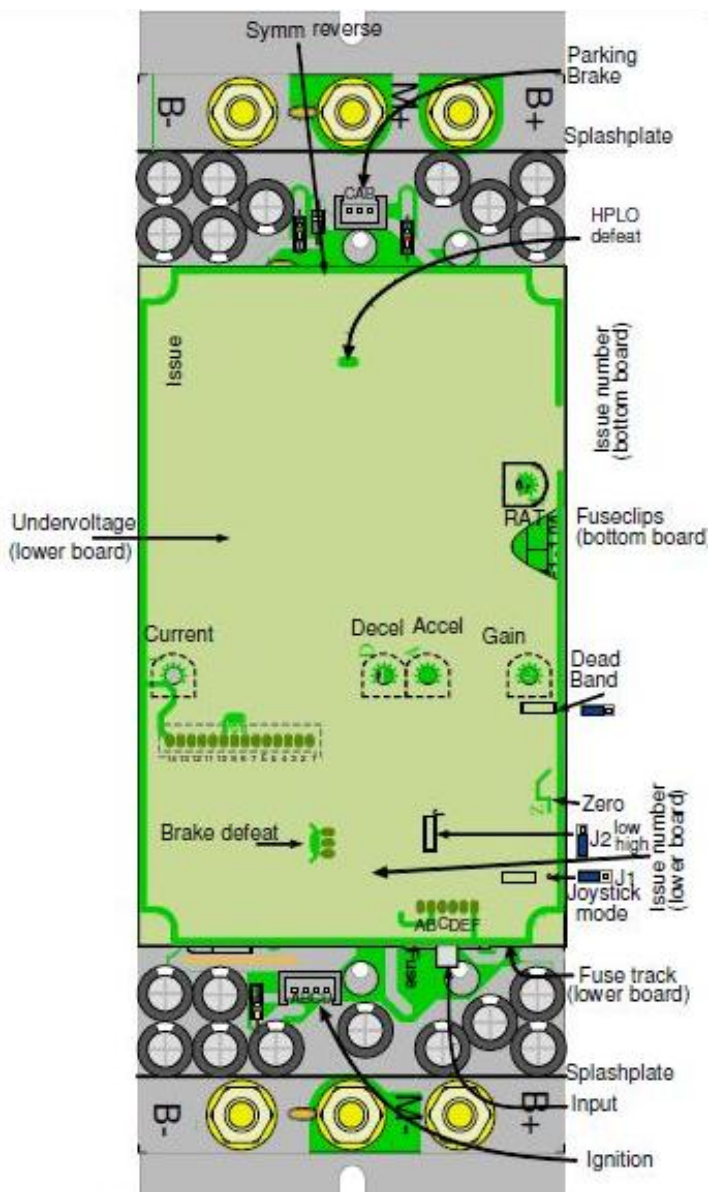

The diagram above shows the key features and adjustments on the 4QD-300 model. This diagram is referenced in the manual to show the position of the features on the board.

6. Power Connections

6.1 Battery & motor wire size

This should be heavy gauge, and will depend on the current anticipated. This table give typical ratings.

Cross sectional area mm2	Amps [85°C]
4	40
6	50
10	70
16	100
25	140
35	185
50	230
70	285

Keep the battery and motor wires as short as possible, excessive battery wiring length will cause reduced voltage to the controller, giving reduced output current, and causing the controllers capacitors to work harder, heat up, and shorten their life.

6.2 Battery Wiring

WARNING; be very careful with the battery wiring. The battery should be the last item you connect, and you should disconnect the battery before changing any other wiring.

It is advisable that the battery leads be clamped to the vehicle's chassis in such a way that the positive lead can only reach the positive terminal, and then only if the battery is fitted the correct way round in the vehicle.

Be warned that, when you connect the battery, there will be a significant spark as the capacitors in the controller charge up. This does not

indicate a fault and is quite normal. Fitting a battery contactor prevents this spark.

Use good quality battery connectors. The 4QD regenerates energy back into the battery during braking, if the battery connection falls off, this energy may cause the voltage on the controller to rise to a destructive level.

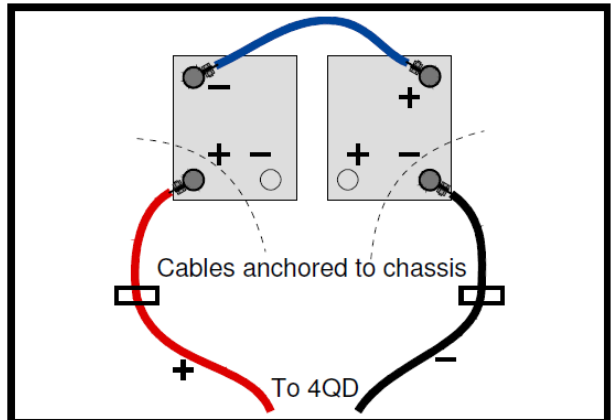

6.3 Under voltage protection

Under voltage protection switches the controller off if the voltage at its terminals drops below a pre-set level. This has two purposes, firstly it protects the controller from the effects of a failed battery, and secondly can prevent damage to a battery caused by excessively discharging it.

If one cell in a battery fails under a high load, the effects can be unpredictable and can blow the controller since the battery voltage can disappear very quickly.

Therefore adjustable battery under voltage protection is fitted. It is adjustable (by means of a preset adjustment on the base board) between about 14v and 40v.

The drawing shows the base board with the control (top) board removed. The adjustment is to the left of the 14 way connector.

Approximate settings are shown below, however if you need an accurate setting we recommend measuring it.

Position	U/V	For Battery
Fully clockwise	40v	
3 o'clock	37v	48v
Centre	27v	36v
9 o'clock	17v	24v
Fully anticlockwise	14v	

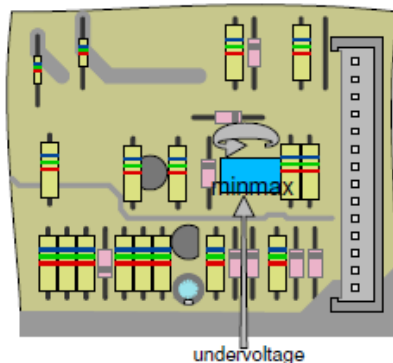

A typical safe level of discharge is around 80% of battery capacity, this corresponds to a voltage of about 10.5v for each 12v of nominal battery voltage.

Lithium Polymer and some other battery chemistries are very sensitive to over discharge. If you are using these we strongly recommend calibrating the under voltage protection setting.

6.4 Motor Wiring

Motor polarity

M+ is positive for forward direction. If the direction is wrong, reverse the M+ and M-wires.

Multiple motors

The controller can be used with multiple motors, the best way of using several motors is to wire them in parallel.

6.5 Noise suppression

It is essential to take steps to reduce electrical noise in any motor control system. This serves two purposes, firstly to prevent the system transmitting interference to others, but more importantly to stop the interference getting into the controllers electronics and damaging the sensitive components inside. We recommend the following;

- Fit motor suppression capacitors directly across the brushes of each motor to catch noise from brush arcing.
- Fit ferrite rings to each motor wire, these reduce high frequency noise not caught by the capacitor travelling along the motor wires.
- Twist the motor wires together. This stops them forming a loop antenna.
- Fit transient suppressors to any system likely to suffer voltage spikes. These include automotive applications, fighting robots, and anything where there will be rapid changes to the motor speed and direction.

7. Control Connections

7.1 Simple Wiring Diagram

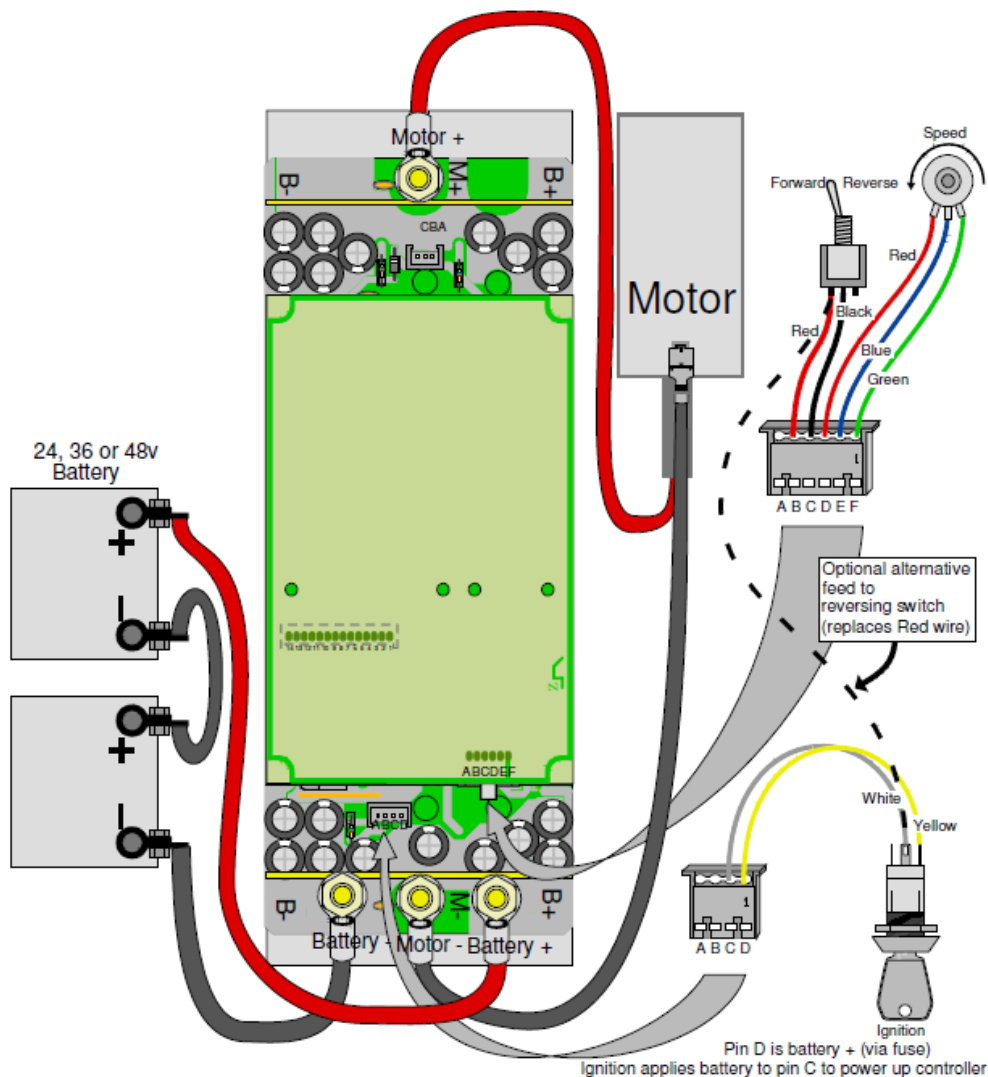

Control Wiring

The control wiring can all be thin and does not generally need to be screened*, unless it runs close to the motor or battery wiring. There is a fuse track in the control circuitry - see 0.

*Note: we do recommend screened cable for fighting robots or other applications likely to have large surge loads.

Connectors

Insulation Displacement Connectors [IDC] are supplied with the controller. These are easier and more reliable than screw terminals, crimps or soldered connections. You do not need to strip the insulation from the wire before using it, simply push the wires into the connector and squeeze it closed.

You must however use the correct wire which is flexible 7/0.2 (7 strands, each 0.2mm). The nearest US equivalent is: 24 AWG (commonly 7 strands of 32 AWG).

Wire which is too thin will not make contact. Wire which is too thick will damage the tines. Single conductor (telephone cable) wires will fatigue and break.

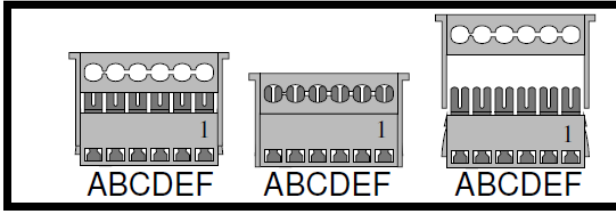

The diagram shows the 6 way connector: open, closed and dismantled, the letters correspond with the 'Features' diagram.

With the connector open, push the wires into the holes in the cable grip from the front which is as illustrated. When all the wires are in place, squeeze the connector closed in a vice [gently], or with a pair of parallel jawed pliers, then trim any protruding ends off from the reverse side.

If you need to open a closed connector, it is possible by gently lifting the ears of the cable grip outwards to release them from the latch.

6 way connector

This is for the speed pot, direction, and inhibit controls.

Reverse is selected by applying a voltage to pin C.

Inhibit is via pin A, connect this to 0v to disable the controller.

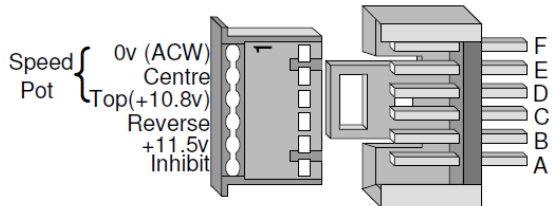

Colour	Function	Connector	Pin
Green	0v to pot	6 pin	F
Blue	Speed [pot wiper]	6 pin	E
Red	11.5v to pot	6 pin	D
Black	Reverse	6 pin	C
Any	12v output [to feed reverse]	6 pin	B
Any	Inhibit input [0v = disabled]	6 pin	A

You may find it easier to insert the 6 way connector if you temporarily undo the 4 control board mounting screws.

4 way connector

This is principally for the 'ignition' switch which connects between +Batty and 'Ignition'. When closed the controller is turned on. The current through the switch is very small so a low current switch may be used. The ignition is operated by a voltage so it can be operated by applying a voltage from a source other than the +Batty pin.

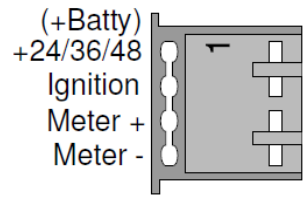

There are two spare pins, one connected to the 'ignition line and the second to 0v (battery -) for a battery condition meter or a reverse polarity protection relay.

3 way connector

This is for the electromagnetic parking brake [if fitted] which connects between battery +ve and the centre pin. A third pin (0v or battery -) is supplied in case a brake override switch is required.

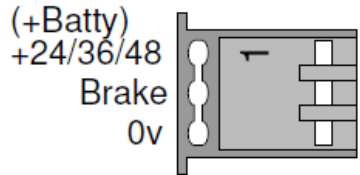

7.2 Ignition light

An LED may be fitted to act as an Ignition light.

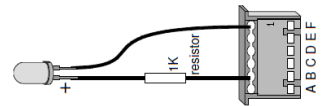

8. Inputs

8.1 Speed control pot

This is essentially the same whether you use joystick or single ended mode. A 10K pot is suggested, but you can use any value from 1K to 22K. Higher pot values will cause the pot fault detection to operate. Wiring for both modes is shown below.

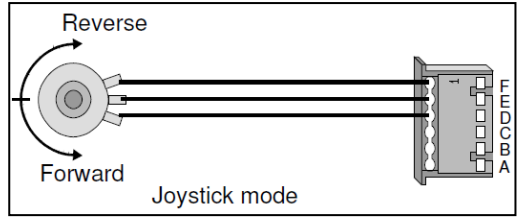
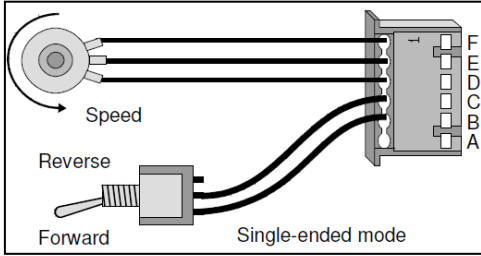

Top speed adjustment

This can be achieved via the gain control, but this is an optional wiring scheme for those who wish to have an external adjustable limit to the output power.

Either use a switch and a fixed resistor or use a pot in series with the wiper of the main speed pot. A resistor (or a pot) of 62K will halve the top speed. A 200K pot would give a 3:1 top speed range. The diagram shows both the pot and the switch plus resistor but only one should be used.

Alternatively if it better suits the wiring, a resistor may be inserted in series with the top end of the pot. 10K with a 10K pot would halve the speed. Take care not to exceed about 30K pot plus series resistor or the pot fault circuit may cut in.

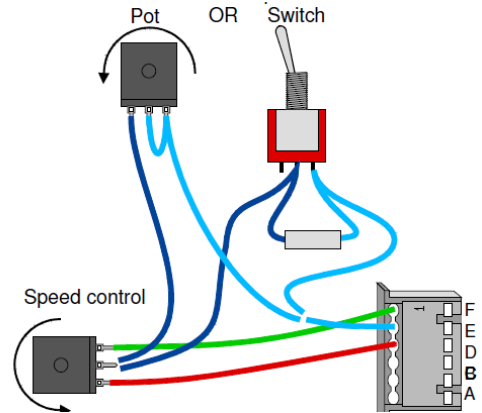

Battery meter

If a battery condition meter is required it can be conveniently connected to the 4 way connector. Meter +ve is internally connected to the 'ignition' line - which is the battery positive, switched by the ignition switch so the meter is off when the ignition is off. Meter -ve is internally connected to battery -ve.

Voltage control

All of the inputs on the 4QD controllers can be voltage controlled.

Speed is controlled by the voltage (0-3v minimum) on pin E of the 6 way connector. However when using a voltage you must fit a 10K resistor in place of the pot between pins D and F or the 'pot fault detection' circuit will engage. This enables two controllers to be fed from the same pot: the common speed pot is connected

normally to one controller and pins E on both controllers are joined. Ignition pins can be joined, as can reverse pins.

Joystick (wig-wag) mode and Input deadband

Factory default positions of the headers are shown on the features diagram. Mode and deadband interact if low dead-band is engaged. As supplied, the controller is set up for 'single-ended' mode (speed and separate reverse switch) and high dead-band. Mode is changed by moving the 'header' J1.

In Joystick mode, J2 must be set to the factory default. However if the Dead-band is set to low in single-ended mode, then the header J2 must be moved (or removed) or reversing will not properly operate. J2 disconnects Joystick direction control so must be as supplied for Joystick mode. It is possible to electrically centre the joystick by using the 'zero' point indicated on the 'features' diagram. However - mechanical centering is better and should generally be used in preference.

A table of link positions is given at the end of this manual.

8.2 Reverse

Reverse is engaged if more than 5v is applied to pin C of the 6 way connector on the top board. For convenience a 12v output is supplied on pin B, but battery +ve can be used instead if it simplifies the machine wiring. The maximum allowable voltage on pin C is 60v.

A reverse switch is only needed if the controller is switched to single ended mode. If you use a reverse switch in joystick mode you will not be able to go forward when the switch is closed - both joystick directions will be reverse

Be careful not to apply 12v to pin B of the 6 way connector, it is an internal circuit and can be damaged if this occurs.

8.3 Inhibit

Pin A of the 6 pin connector is an inhibit input. When Pin A is shorted to 0v [battery -ve] the controllers output will be turned off. If the motor is driving at the time inhibit is selected this will act as an emergency stop. Removing the inhibit allows the controller to follow the ramp setting up to the demand speed.

Typical uses of this can be in conjunction with a handbrake or a Deadman's handle.

Inhibit may also be used with a footbrake; if the deceleration ramp is set to maximum time, regen braking will have little effect and the vehicle can be stopped on the footbrake. The controller (issue 10 top boards and later) detects that the motor speed is reducing faster than the internal deceleration ramp and automatically ramps controller's internal demand speed down to match the mechanical braking.

Note; the inhibit input bypasses the HPLO function, the controller will always start when the inhibit is removed regardless of the throttle position.

9. Braking

Electrical [regenerative] braking relies on the motor acting as a generator. When the vehicle is stopped (or at very low speeds) no electrical braking is possible and the vehicle is free to roll.

9.1 Parking brake

Some motors have an electromechanical parking brake fitted which locks the motor when no power is applied to it. The controller automatically applies power to the parking brake (to disengage it) as acceleration is applied, and removes power a fraction of a second after the motor stops rotating.

The brake solenoid should be connected between battery +ve and 'Brake' (pin B) on the 3 pin connector. The brake output is suitable for solenoids drawing up to 1A. A spare battery -ve connection is present in case you wish to fit a manual brake release switch. The diagram shows how a 2 position switch can be used to give release – normal operation.

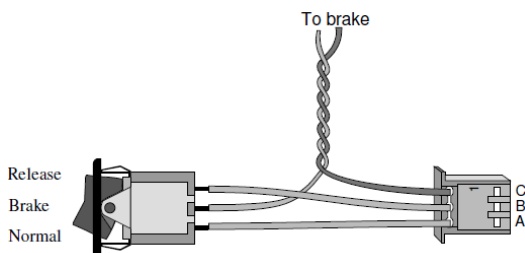

9.2 Mechanical brake

The parking brake on a motor [if fitted] will only come on when the motor is rotating very slowly. Therefore, on steep hills the regenerative braking works but the parking brake won't come on. For safety a separate mechanical braking system must be fitted to any passenger carrying vehicle.

10. Adjustments

There are several adjustments that can make a significant difference to the way the controller behaves. It is supplied as standard with all adjustments set to suit a typical application, so you may not have to alter anything.

The location of these adjustments is given in the features diagram.

10.1 Gain

The purpose of the gain control is to match the output of the controller to the speed pot arrangement, it is marked on the features diagram and has a G against it on the circuit board.

To set the gain, first ensure the drive wheels are clear of the ground and free to rotate.

- Switch the controller on and select forward direction.
- Open the throttle and wait for the controller to ramp up to full speed.
- Adjust the gain preset pot until the wheel speed is just at maximum [or whatever speed is required at full throttle].

If the gain adjustment is too low the vehicle will not reach it's top speed. Note; the gain control can be used to limit top speed if required.

If the gain adjustment is too high the controller will reach full speed before the throttle pot reaches maximum deflection.

The gain can also be set by using a voltmeter across the M+ / M- terminals, you should see full battery voltage at full throttle. Alternatively if an oscilloscope is available check the duty cycle of the waveform on the M- terminal with respect to B-.

10.2 Ramps

These control how sharply the machine accelerates or decelerates when the throttle is opened. Adjust them by trial and error to match the vehicle's performance to your requirements.

Acceleration. Electric motors make maximum torque at very low speeds, a sudden application of the throttle will cause a sudden surge of power. The preset marked A on the diagram adjusts the acceleration rate. Too long an acceleration time (clockwise) and the vehicle will be slow to pick up speed. Too fast a rate and the vehicle may wheel spin. Factory setting is at about 12 o'clock'

Deceleration rate is adjusted by the preset marked D. Too slow a deceleration and the regenerative braking will be low, too sharp a deceleration can cause skidding. Factory setting is at about 12 o'clock.

Note; fast deceleration can cause large regeneration currents to flow. In some circumstances these currents can cause the battery voltage to rise above the over voltage protection threshold [68v] causing the controller to switch off. If the application includes rapid deceleration we recommend fitting a suitable transient suppressor, see our website knowledge base for details.

The ramp times are variable between 0.1S to 5S. 4QD can alter the adjustment range for various uses if required.

10.3 Current limit

This is set at maximum as default. It can be adjusted if

- You wish to limit the stall current drawn by the motor.
- You wish to limit the torque delivered at low rpm.

10.4 RAT

The Reverse Acceptance Threshold controls the motor speed at which the controller will reverse. Normally the controller should reverse the motor just before it is completely stopped. It may need slight reduction for higher battery voltages and / or for low rolling friction vehicles.

10.5 Reverse Speed.

As supplied, maximum reverse speed is around half forward speed. On the top board there is a pinstrip and header link marked "symm reverse" on the features diagram which may be unplugged. With the header removed reverse speed will be the same as forward speed. It is also possible to fit a trimmer potentiometer to give an adjustable reverse speed. Contact 4QD for information.

10.6 High pot lockout [HPLO]

The controller is fitted with a protection mechanism which disables it at switch on if the throttle pot is not at zero speed. This safety feature can be disabled by bridging out the link point marked HPLO on the control board.

10.7 Regen brake defeat.

Regenerative braking can be disabled by linking out the point indicated (Brake Defeat or BD) on the features diagram.

11. Heatsinking and Output Current

The available output current depends on the temperature. A 4QD-300D controller, connected to a stalled motor will give between 300 and 330 amps when cold, decreasing as the unit heats up until the overheat thermostat cuts in. In normal operation full current is generally only required intermittently. However, the controller may warm up and if the load profile is high the overheat thermostat will cut the controller off. The time taken to overheat is load, mounting, and cooling dependant and is therefore not easily predicted. The heatsink supplied is adequate for most requirements, but enhanced air and water cooling options are available.

It is not good practice for electronic equipment to be allowed to run too hot. If the heatsink runs uncomfortably hot to the touch then extra cooling should be considered, even if the overheat thermostat doesn't operate.

12. Battery Charging

Unless a circuit breaker or battery switch has been fitted, the controller is permanently connected to the battery. It is ok to charge the battery while it is connected to the controller.

13. Fault Finding

Experience has shown that most faults are due to problems in the external wiring, and this is the first area that should be checked.

The controller has many safeguards to restrict damage if there is a problem and an understanding of the safeguards should assist in finding faults.

All voltage measurements should be made with meter negative on the battery negative terminal.

The ignition switch applies battery voltage to pin C of the 4 way connector. This enables the controller's internal 12v power supply, until this supply is on the controller is dead. The internal supply can be measured on pin B of the 6 way connector. The supply also feeds (via the pot fault detection circuit) the top of the throttle pot, pin D, where you should measure around 11.4 volts.

As the throttle pot is moved it applies a variable voltage to pin E of the 6 way connector. There is a 'high pedal lockout' circuitry which prevents the controller taking off at high speed if the throttle is faulty: this resets itself when the voltage on pin E falls to zero.

So check that the throttle voltage varies from 0v upwards. The pot top voltage should be 11.4 or below. In joystick mode 'zero speed' is about 5.5v on pin E.

If the 12v is correct and the pot voltage is altering from zero upwards there is a fault in the controller.

Dead or loss of power

Check that high pot lockout is not occurring.

Check that under voltage protection is not operating. Under voltage protection cannot tell the difference between a flat battery and a poor connection or wire that is too thin. It can be useful to connect a voltmeter directly across the B+ / B- terminals and measure the voltage the controller is seeing whilst under load.

Check the fuses as described in the fuses section.

Other faults

More troubleshooting tips can be found in the support section of our website.

14. Fuses

A 'fuse' track is present on the controller base board. It is shown on the Features diagram, and is there to limit damage to the controller in the event of an external fault in the ignition or parking brake wiring.

This fuse cannot be blown by any fault in the controller. If it blows, the internal power supply will be off and the controller will be dead. Two empty fuse clips are provided on the base board where a standard 20mm fuse (1.0 amp) may be fitted if the track blows.

The track to Pin F of the 6 way connector can also blow in the event of an earth fault in the pot wiring.

If either track fuses, find and correct the cause of the fusing before proceeding.

15. Link positions

The links are located on the component side of the control board.

Dead band= high [centre of PCB = default]		J1 position	
		single ended	joystick
J2 position	low	normal	one direction from centre of pot, rev via switch
	high	normal	Fwd / rev from centre of pot. Rev switch prevents fwd

Dead band = low [edge of PCB]		J1 position	
		single ended	joystick
J2 position	low	normal	no action
	high	no action	no action

16. Dismantling

The 4QD series should not need to be dismantled under normal circumstances. If this does become necessary, for instance if the base plate requires machining during assembly, full instructions are in the knowledgebase section of our website.

17. Service

In the event of any problem please contact us before returning a suspect controller. Please include a completed returns form with the returned controller [see website]. Details of service charges are on the website.

Warranty

All our controllers have a warranty against defective manufacturing for 12 months from the date of shipment. The warranty doesn't cover damage caused by incorrect installation.

18. Specifications

Model	200	300
Nominal voltage range	24 – 48	
Minimum / maximum voltage	18-66	
Motor current A [max]	230	320
Motor current A [1 minute]	140	180
Motor current A [continuous]*	depends on cooling	depends on cooling
Reversing	Y	
Half speed reverse	Link selectable	
Regen braking	Y [can be disabled]	
Gain adjustment	Y	
Dimensions [mm]	250 x 103 x 60	280 x 103 x 60
Weight [g]	1300	1685
Power connections	M6 studs	M8 studs
Input	5k – 20k pot, or 0 – 3V [adjustable via gain]	
Reverse polarity protection	N	
Over voltage protection	Y [68V]	
Under voltage protection	Y	
Pot fault protection	Y [>40k]	
Thermal protection	trip @95°C	
Current limit – drive	Y [Adjustable]	
Current limit – regen	Y	
High pot lockout	Y	
Joystick/Wig-wag input	Link selectable	
Radio Control	Via DMR-203	
Selectable dual ramp reversing	Y	
Pre-select reversing	N	
Ramping	Acceleration and deceleration adjustable between 0.1S and 5S	
Parking brake	Y [1A max]	
Inhibit function	Y	
Power down state (motor)	open-circuit	
Tacho feedback	Via tacho interface board and mod	
Ignition, Electronic	Y	
Heatsink	Integral	
Double heading	Y	
Switching frequency	20 kHz	
Quadrants	4	